

Course Selection

Grade 9 going into grade 10.

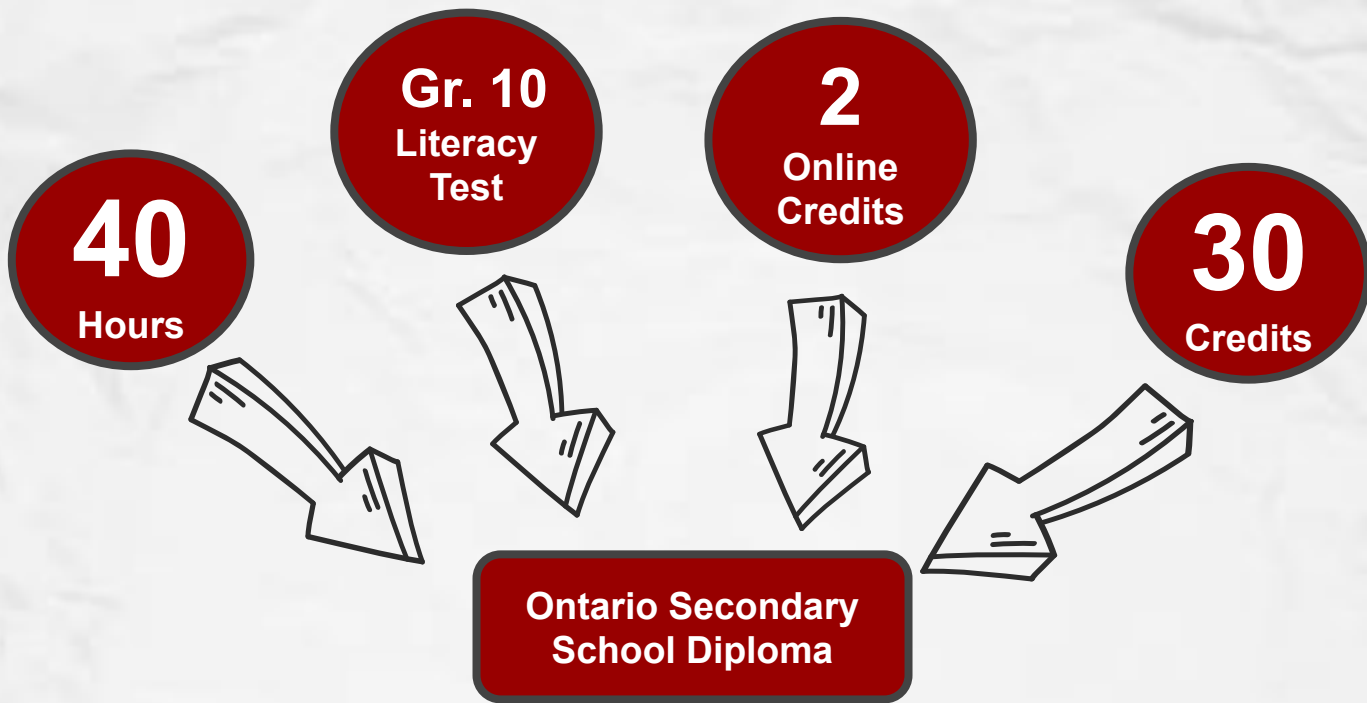

40
Hours

Gr. 10
Literacy
Test

2
Online
Credits

30
Credits

**Ontario Secondary
School Diploma**

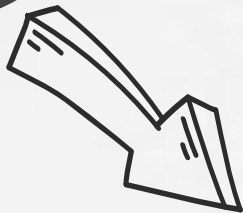

40
Hours



www.volunteerwr.ca

40
Hours

Online
Submission



www.bit.ly/res_volunteer

Future Phoenix Parents Academics Student Support Student Life About Us Search

Home / Student Supports / Guidance

Guidance

APPOINTMENT BOOKINGS

- Mr. Kriz (A - Ch), ACTIVE & Community Living Program
- Ms. Iley (Ci - Gi) & International Students
- Ms. McQuinn (Gl - Ma)
- Mr. Meyer (Mc - R) & ELD program
- Ms. Jayasundera (S - Z)
- Ms. Moss (SHSM)

Request a Transcript

Online Learning Opt-Out Form

Submit Community Service Hours

Course Offerings

SHSM

Volunteer Opportunities

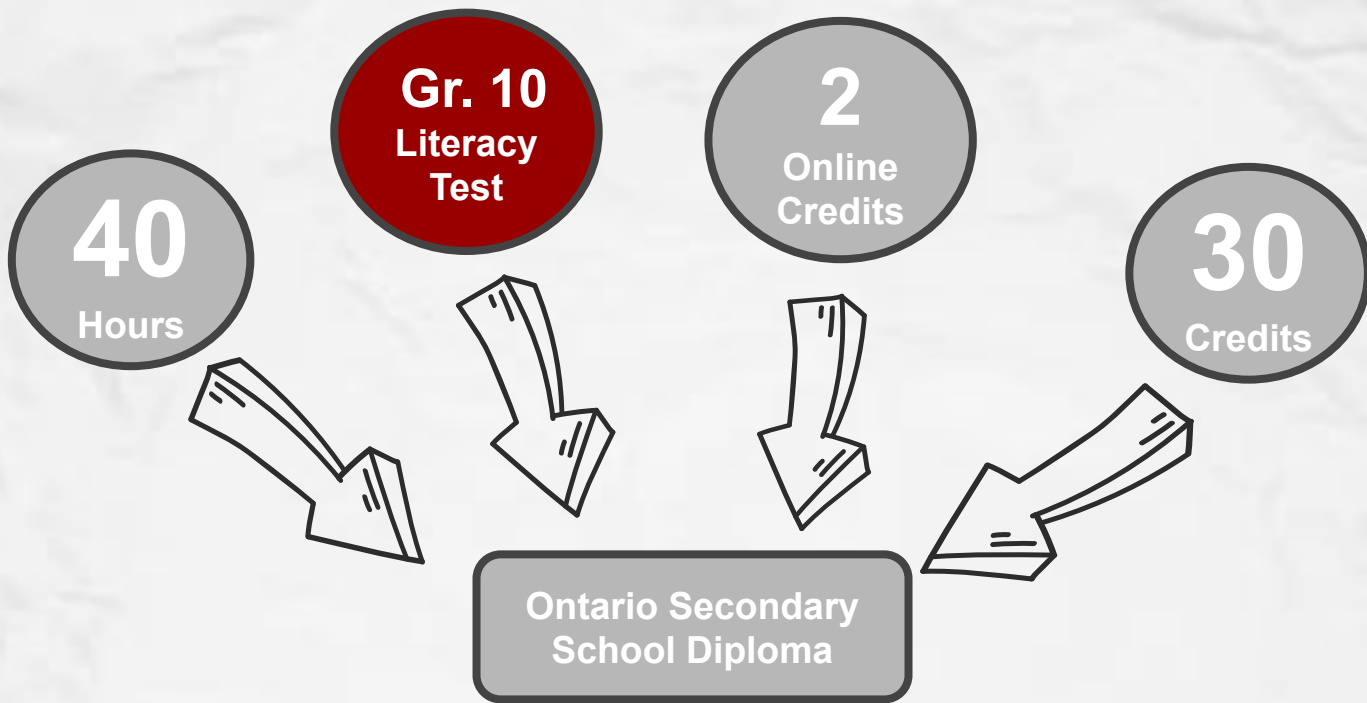

**Gr. 10
Literacy
Test**

- **2026 - 2027**
- **ONLINE - during school time**
- **Supports and information will be provided.**



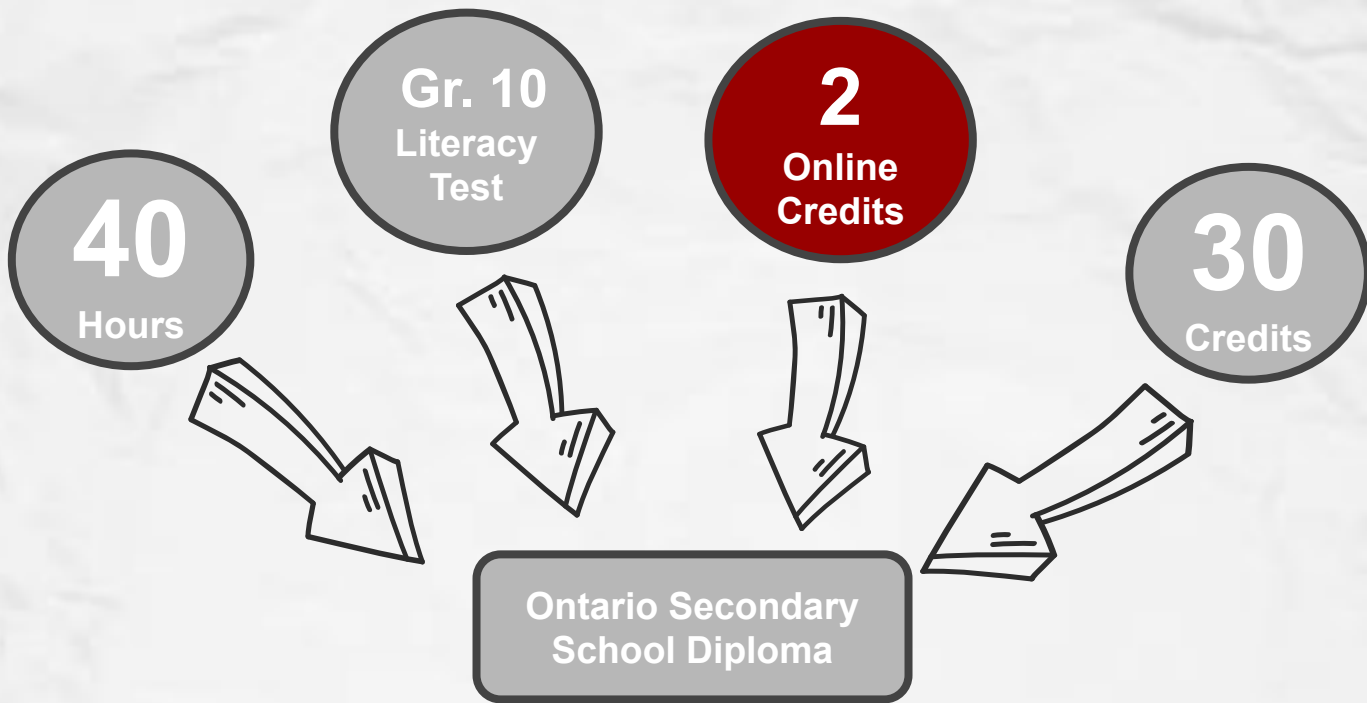

2

Online
Credits

- **Asynchronous**



2

Online
Credits

- Asynchronous
- **Anytime**



2

Online
Credits



- Asynchronous
- Anytime
- **Summer School
(Careers/Civics)**

2

Online
Credits



- Asynchronous
- Anytime
- Summer School
(Careers/Civics)
- **Opt out process**

2

Online Credits



www.bit.ly/res-optout

- Asynchronous
- Anytime
- Summer School (Careers/Civics)
- **Opt out process**

Future Phoenix Parents Academics Student Supports Student Life About Us Search

Guidance

Home / Student Supports / Guidance

APPOINTMENT BOOKINGS

- + Mr. Kritz (A - Ch), ACTIVE & Community Living Program
- + Ms. Iley (Ci - Gi) & International Students
- + Ms. McQuinn (Gl - Ma)
- + Mr. Meyer (Mc - R) & ELD program
- + Ms. Jayasundera (S - Z)
- + Ms. Moss (SHSM)

Request a Transcript

Online Learning Opt-Out Form

Submit Community Service Hours

Course Offerings

SHSM

Volunteer Opportunities



Grade 10 Compulsory

History

Science

Math

English

Religion

Careers/Civics

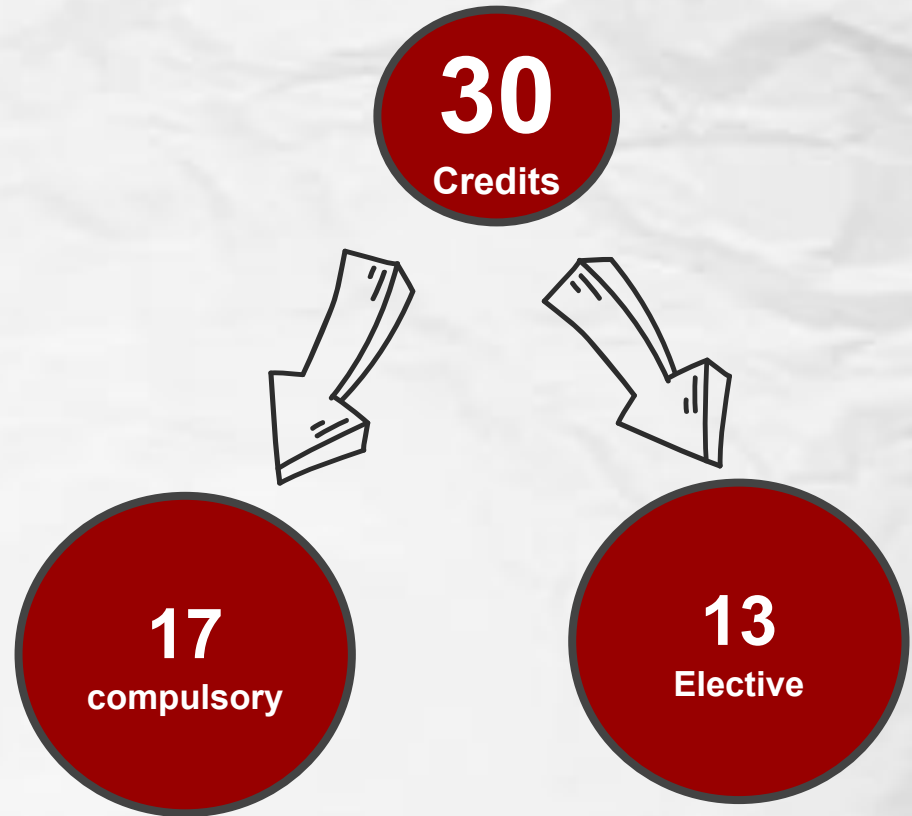

PATHWAYS

Grade 9

Locally
Developed
(L)

De-streamed
(W)

Grade 10

Locally
Developed
(L)

Applied
(P)

Academic
(D)

Grade
11 & 12

Workplace
(E)

College
(C)

University /
College (M)

University
(U)

Post
Secondary

College (Some)
Apprenticeship
Workplace

College
Apprenticeship
Workplace

University
College
Apprenticeship
Workplace

17
compulsory

Locally Developed

Applied

Academic

17
compulsory

	Locally Developed	Applied	Academic
Pace	Decreased compared to destreamed	Similar to destreamed	Increased compared to Destreamed

17
compulsory

	Locally Developed	Applied	Academic
Pace	Decreased compared to destreamed	Similar to destremaed	Increased compared to Destreamed
Class Size	Smaller (10-15)	Similar or smaller (20-25)	Larger (25-30)

17
compulsory

	Locally Developed	Applied	Academic
Pace	Decreased compared to destreamed	Similar to destreamed	Increased compared to Destreamed
Class Size	Smaller (10-15)	Similar or smaller (20-25)	Larger (25-30)
Assessments	Project based Fewer tests	English - Project based, some tests Math - Frequent quizzing Science - Study sheets for tests, Frequent quizzing	English - Some projects, more tests Math - Larger Unit tests Science - No study sheets on tests, Larger Unit tests

17
compulsory

	Locally Developed	Applied	Academic
Pace	Decreased compared to destreamed	Similar to destreamed	Increased compared to destreamed
Class Size	Smaller (10-15)	Similar or smaller (20-25)	Larger (25-30)
Assessments	Project based Fewer tests	English - Project based, some tests Math - Frequent quizzing Science - Study sheets for tests, Frequent quizzing	English - Some projects, more tests Math - Larger Unit tests Science - No study sheets on tests, Larger Unit tests
Type of Learning	Teacher centered Hands on	Teacher centered Hands on	Student centered Independent learner



17
compulsory

	Locally Developed	Applied	Academic
Pace	Decreased compared to destreamed	Similar to destreamed	Increased compared to Destreamed
Class Size	Smaller (10-15)	Similar or smaller (20-25)	Larger (25-30)
Assessments	Project based Fewer tests	English - Project based, some tests Math - Frequent quizzing Science - Study sheets for tests, Frequent quizzing	English - Some projects, more tests Math - Larger Unit tests Science - No study sheets on tests, Larger Unit tests
Type of learning	Teacher centered Hands on	Teacher centered Hands on	Student centered Independent learner
Homework	Lower amount compared to destreamed	Similar compared to destreamed	Increased compared to destreamed

Course	Levels			
History	Locally Developed	Applied	Academic	
Science	Locally Developed	Applied	Academic	
Math	Locally Developed	Applied	Academic	
English	Locally Developed	Applied	Academic	AP PREP
Religion	OPEN			
Careers Civics	OPEN			



**Waterloo Catholic
District School Board**
**Pathways through
Mathematics**

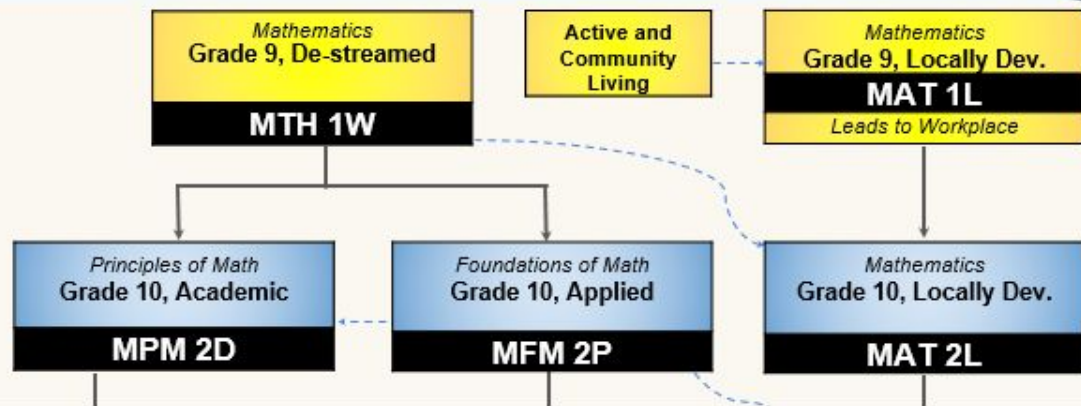

MATH Pathway



**Waterloo Catholic
District School Board**
**Pathways through
Mathematics**

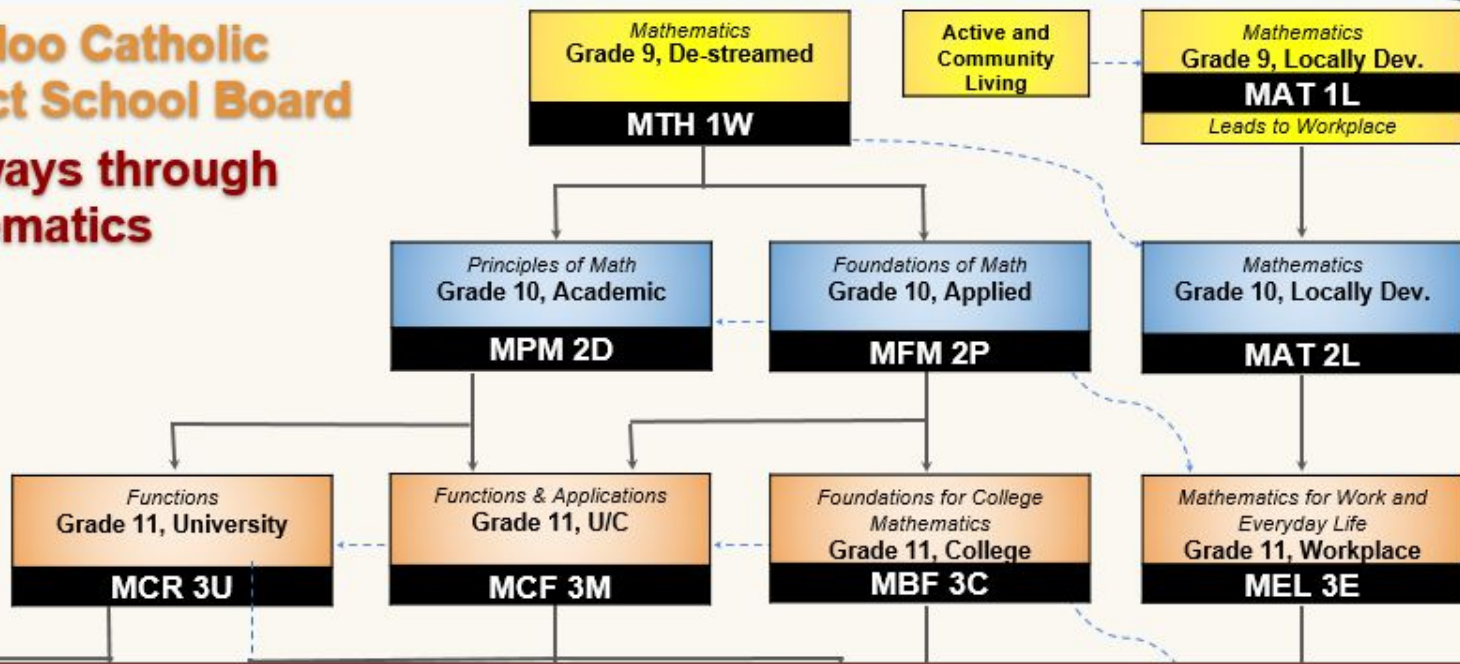

MATH Pathway



**Waterloo Catholic
District School Board**
**Pathways through
English**

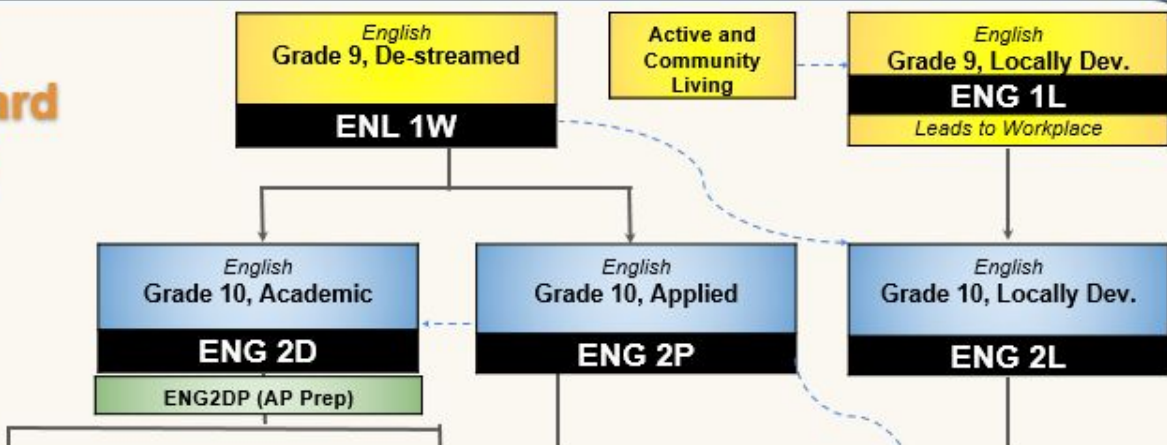

ENGLISH Pathway



**Waterloo Catholic
District School Board**
**Pathways through
English**

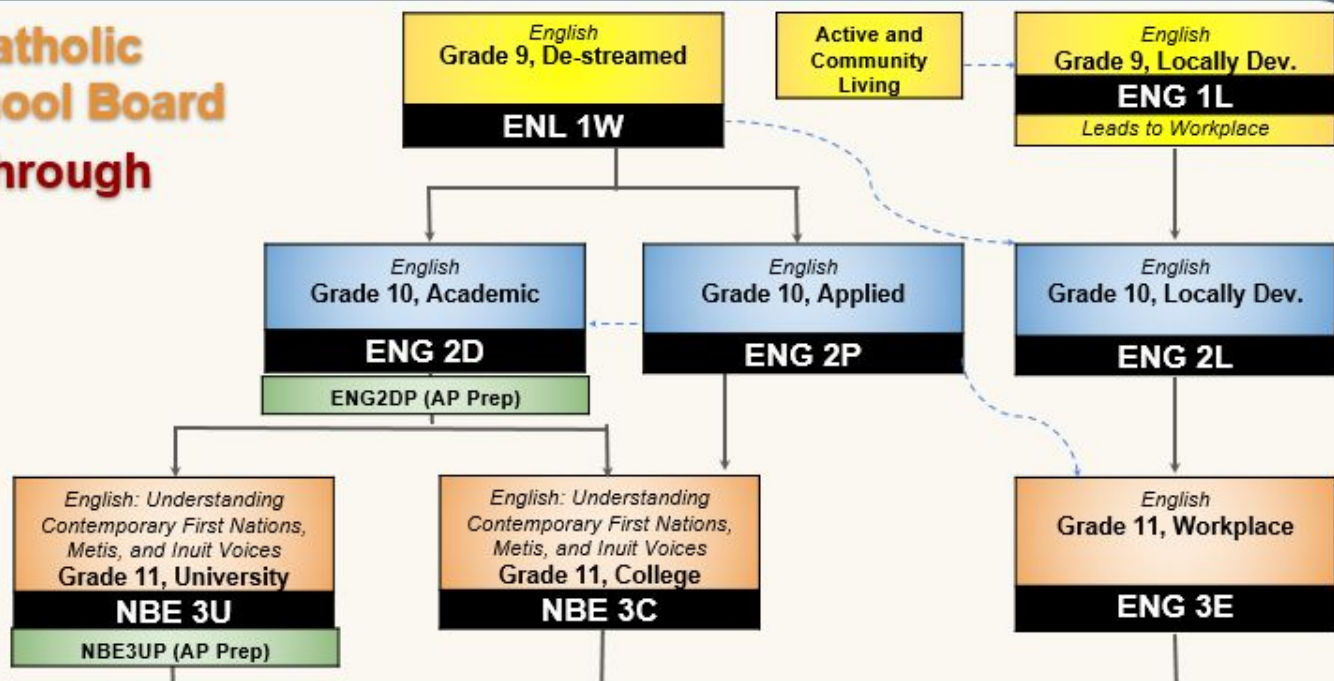

ENGLISH Pathway



Waterloo Catholic District School Board

Pathways through English

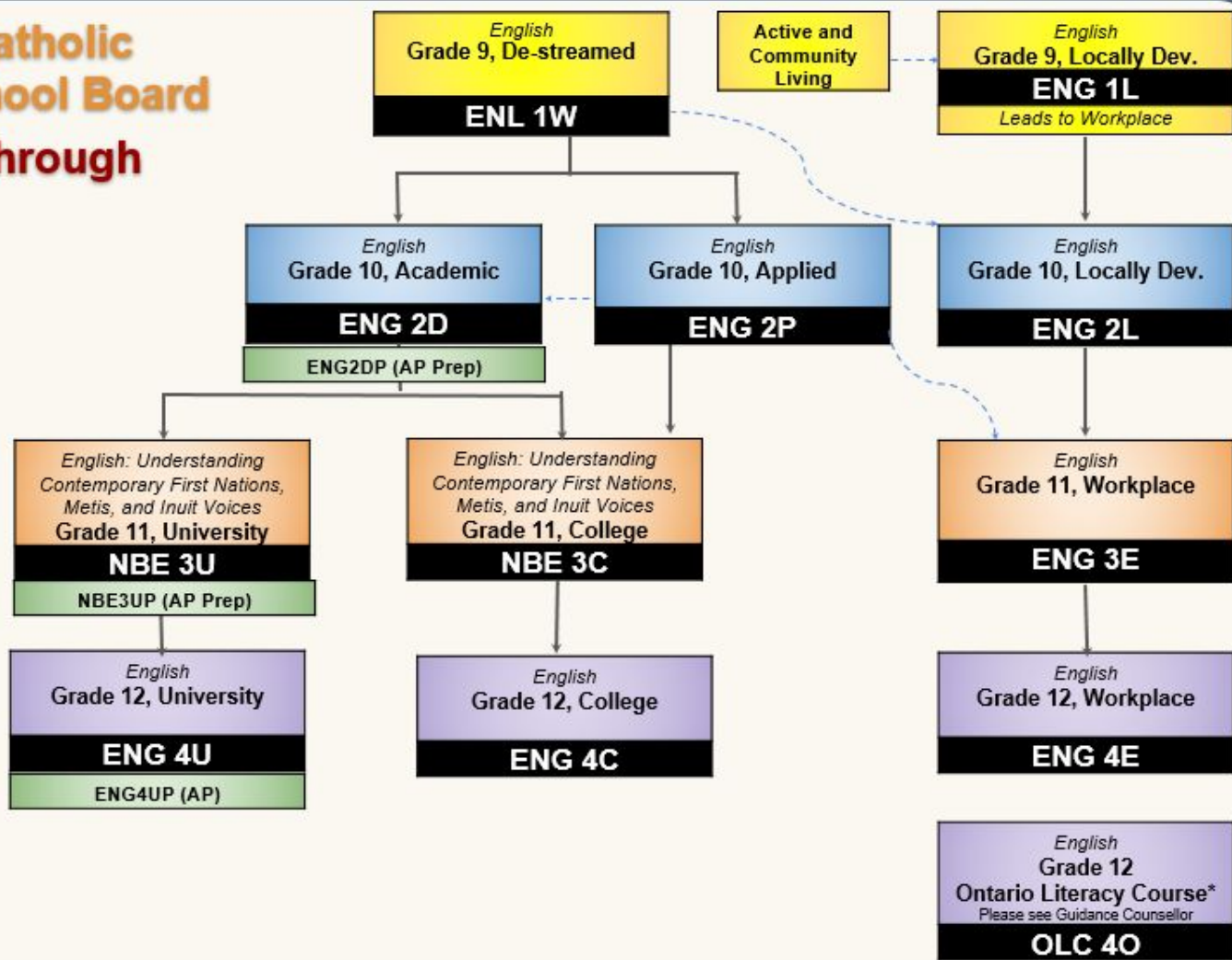



**Waterloo Catholic
District School Board**
**Pathways through
Science**

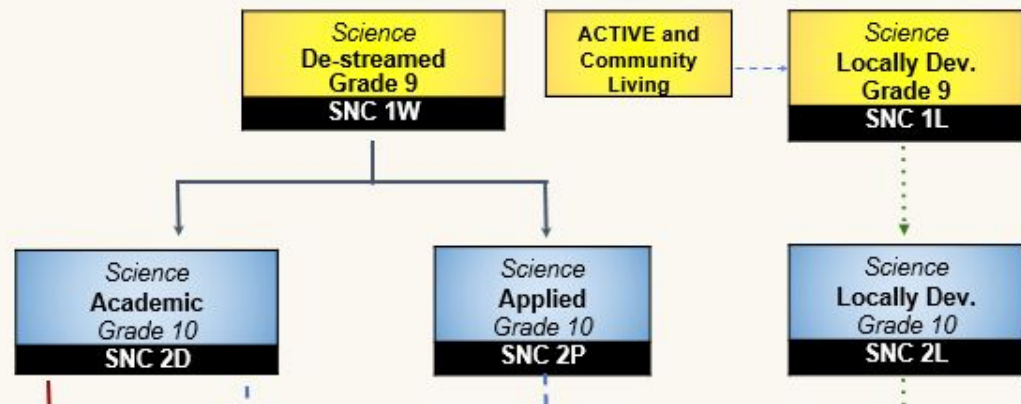

SCIENCE Pathway



**Waterloo Catholic
District School Board**
**Pathways through
Science**

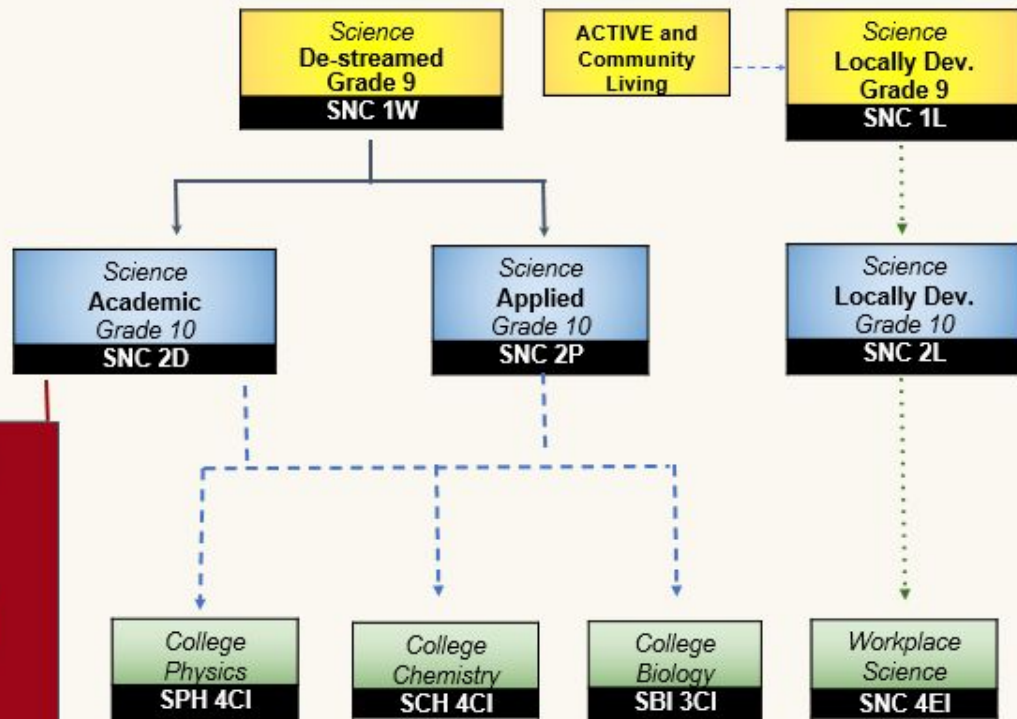

SCIENCE Pathway

Legend

University Pathway Options —

College Pathway Options - - -

Workplace Pathway Options ·····



Waterloo Catholic District School Board

Pathways through Science

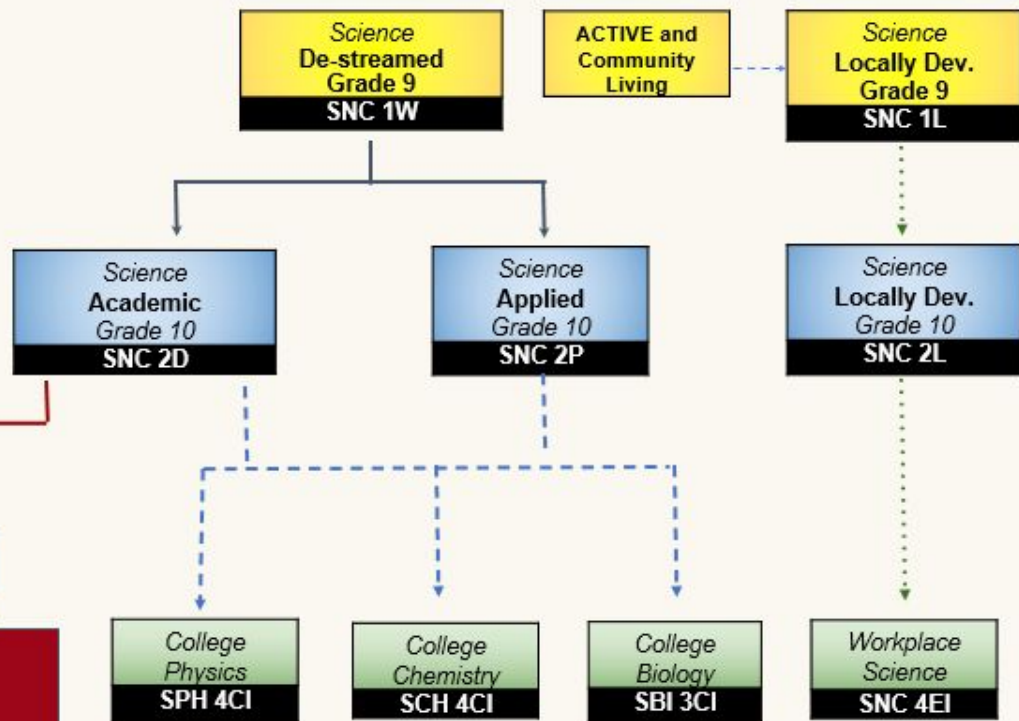

SCIENCE Pathway

Legend

University Pathway Options —

College Pathway Options - - -

Workplace Pathway Options ····



Waterloo Catholic District School Board

Pathways through Science

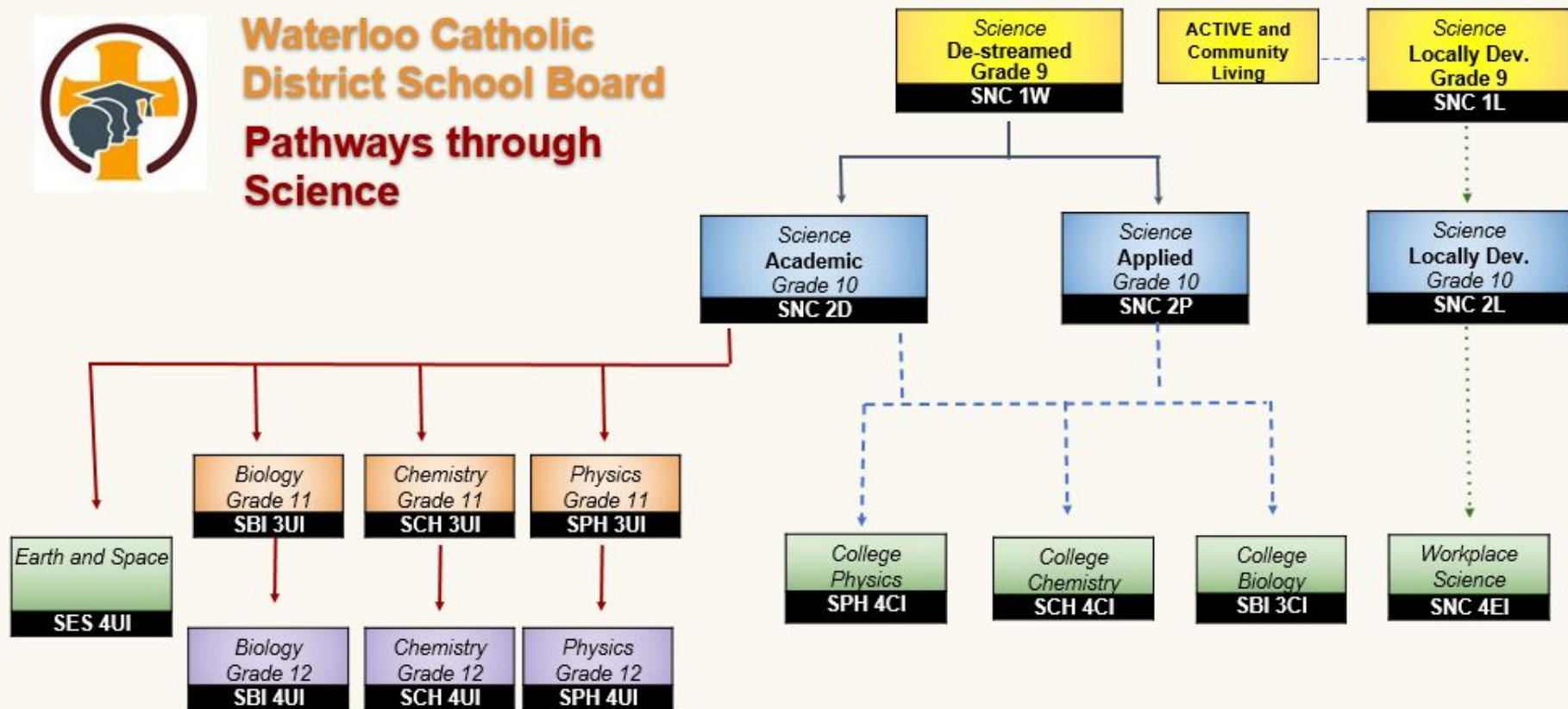

Legend

University Pathway Options ———

College Pathway Options - - - - -

Workplace Pathway Options ·····

Remember:

- 1 Art Credit
- 1 STEM related course
- 1 Phys. Ed. Credit
- 1 Tech

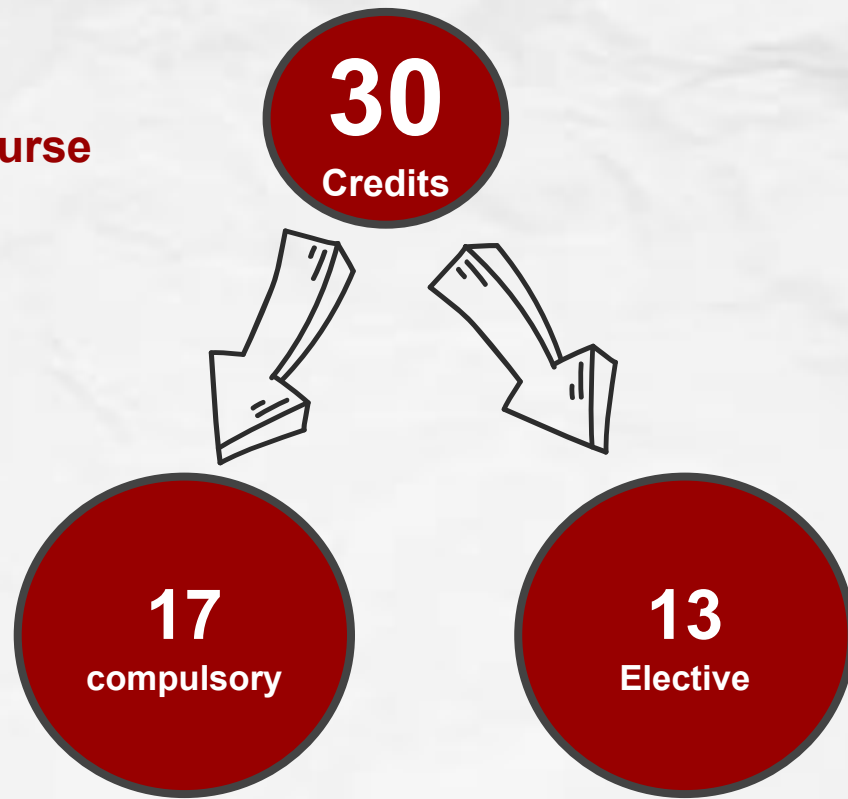

Remember:

- **1 Art Credit**
- 1 STEM related course
- 1 Phys. Ed. Credit
- 1 Tech

STEM related course

- Business
- Computer Studies
- Coop
- Math (gr. 12)
- Science (gr. 11/12)
- 2nd Tech

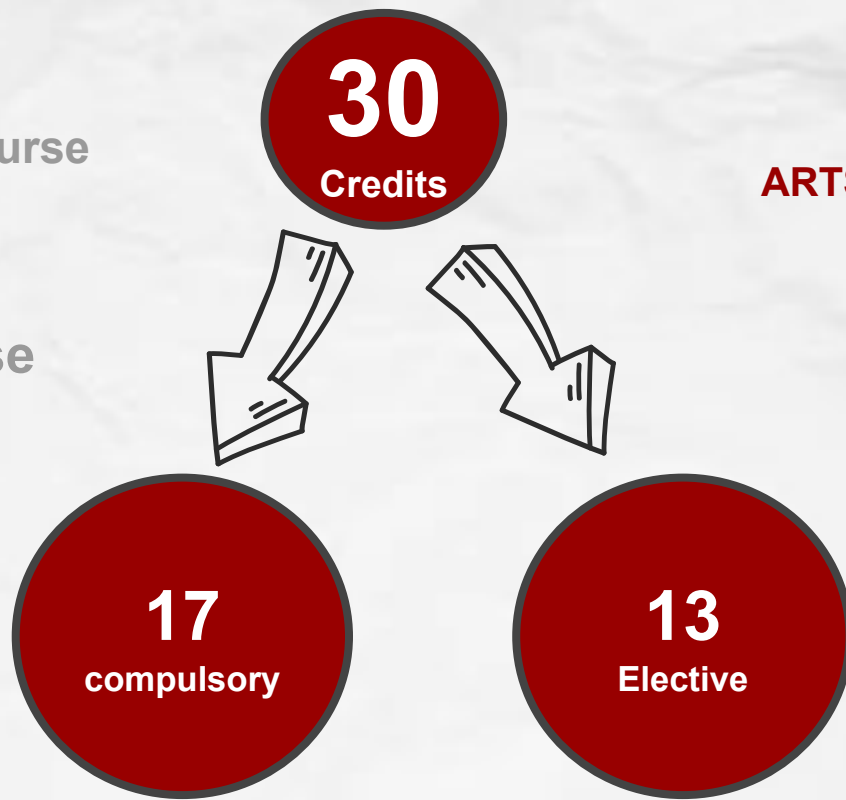

ARTS

- Drama**
- Guitar**
- Instrumental Music**
- Vocal Music**
- Media Arts**
- Dance**
- Visual Arts**
- Arts and Crafts**
- Launching and Leading a Business
- Personal Fitness
- PEAT
- Healthy Active Living
- Construction
- Tech Design
- Hospitality
- Com. Technology
- Green Industries
- Transportation
- Hairstyling

Remember:

- 1 Art Credit
- **1 STEM related course**
- 1 Phys. Ed. Credit
- 1 Tech

STEM related course

- **Business**
- **Computer Studies**
- **Coop**
- **Math (gr. 12)**
- **Science (gr. 11/12)**
- **2nd Tech**

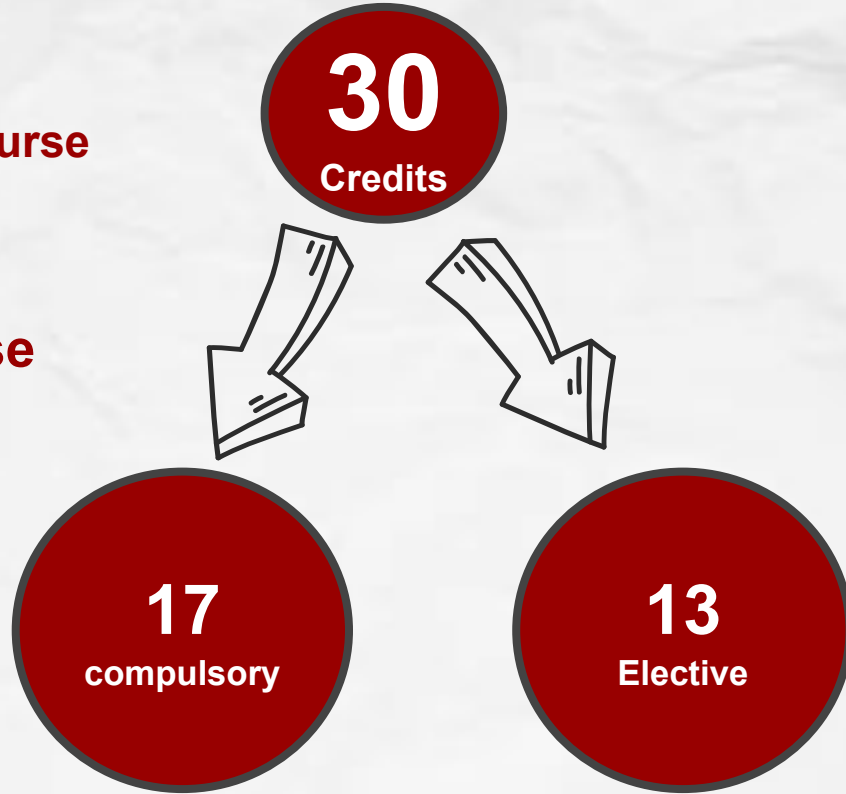

Remember:

- 1 Art Credit
- **1 STEM related credit**
- 1 Phys. Ed. Credit
- 1 Tech Credit

STEM related course

- **Business**
- Computer Studies
- Coop
- Math (gr. 12)
- Science (gr. 11/12)
- 2nd Tech

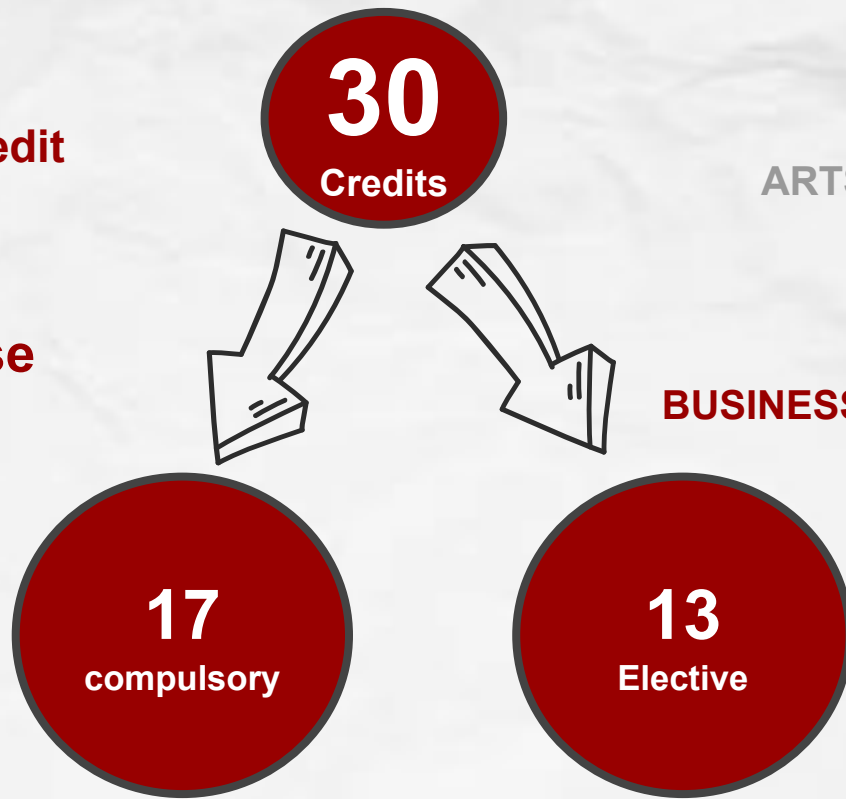

ARTS

- Drama
- Guitar
- Instrumental Music
- Vocal Music
- Media Arts
- Dance
- Visual Arts

BUSINESS

- Arts and Crafts
- Launching and Leading a Business**
- Personal Fitness
- PEAT
- Healthy Active Living
- Construction
- Tech Design
- Hospitality
- Com. Technology
- Green Industries
- Transportation
- Hairstyling

Remember:

- 1 Art Credit
- **1 STEM related credit**
- 1 Phys. Ed Credit
- 1 Tech Credit

STEM related course

- Business
- **Computer Studies**
- Coop
- Math (gr. 12)
- Science (gr. 11/12)
- 2nd Tech

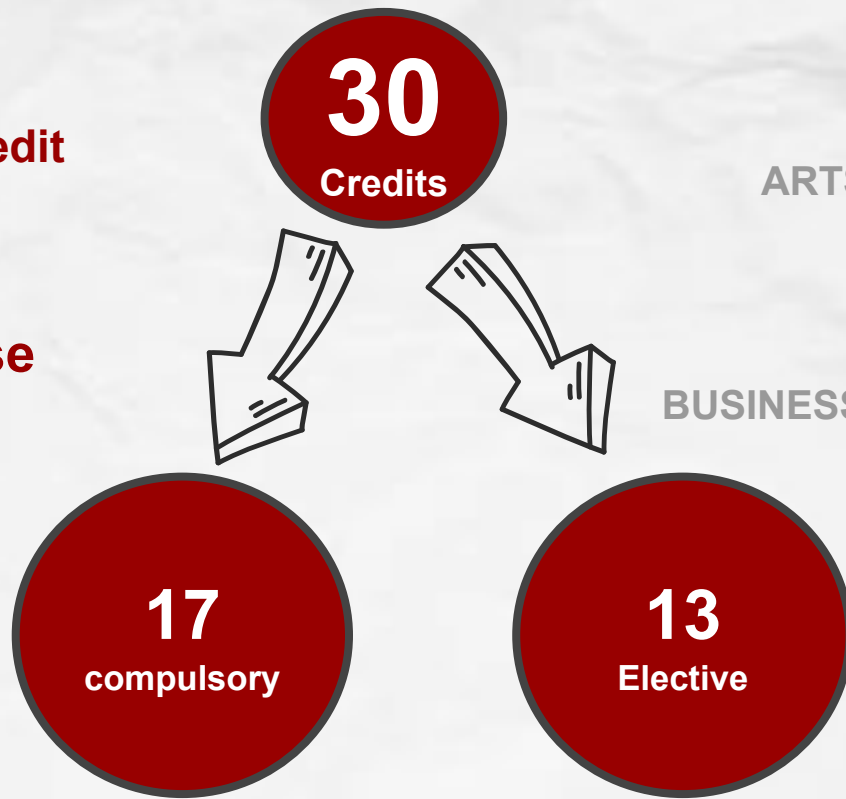

ARTS

Drama
Guitar
Instrumental Music
Vocal Music
Media Arts
Dance
Visual Arts

BUSINESS

Arts and Crafts
Launching and
Leading a Business
Personal Fitness

P.E.

PEAT
Healthy Active Living
Computer Programming
Construction
Tech Design
Hospitality
Com. Technology
Green Industries
Transportation
Hairstyling

Remember:

- 1 Art Credit
- **1 STEM related credit**
- 1 Phys. Ed. Credit
- **1 Tech Credit**

STEM related course

- Business
- Computer Studies
- Coop
- Math (gr. 12)
- Science (gr. 11/12)
- **2nd Tech**

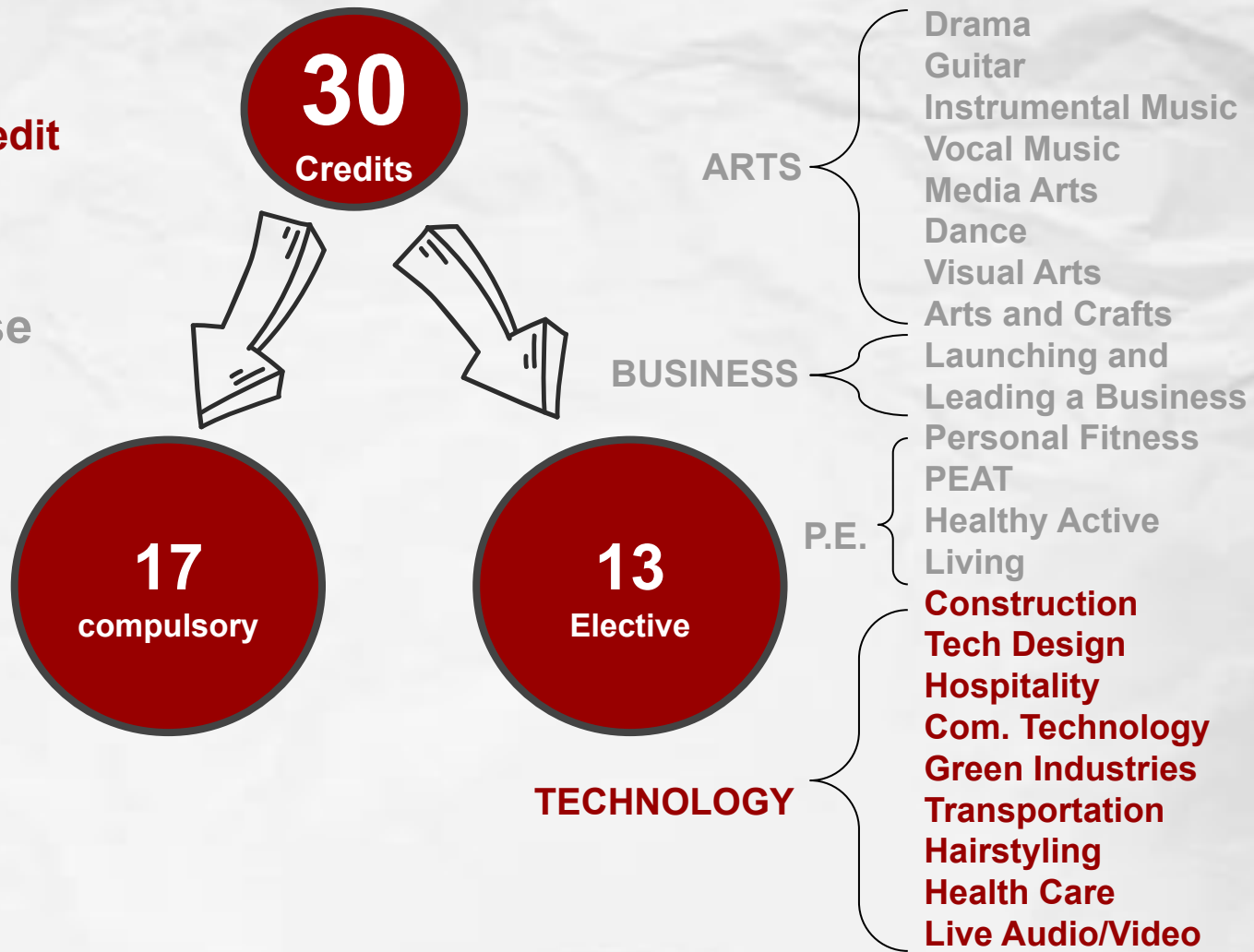

Remember:

- 1 Art Credit
- 1 STEM related credit
- **1 Phys. Ed Credit**
- 1 Tech Credit

STEM related course

- Business
- Computer Studies
- Coop
- Math (gr. 12)
- Science (gr. 11/12)
- 2nd Tech

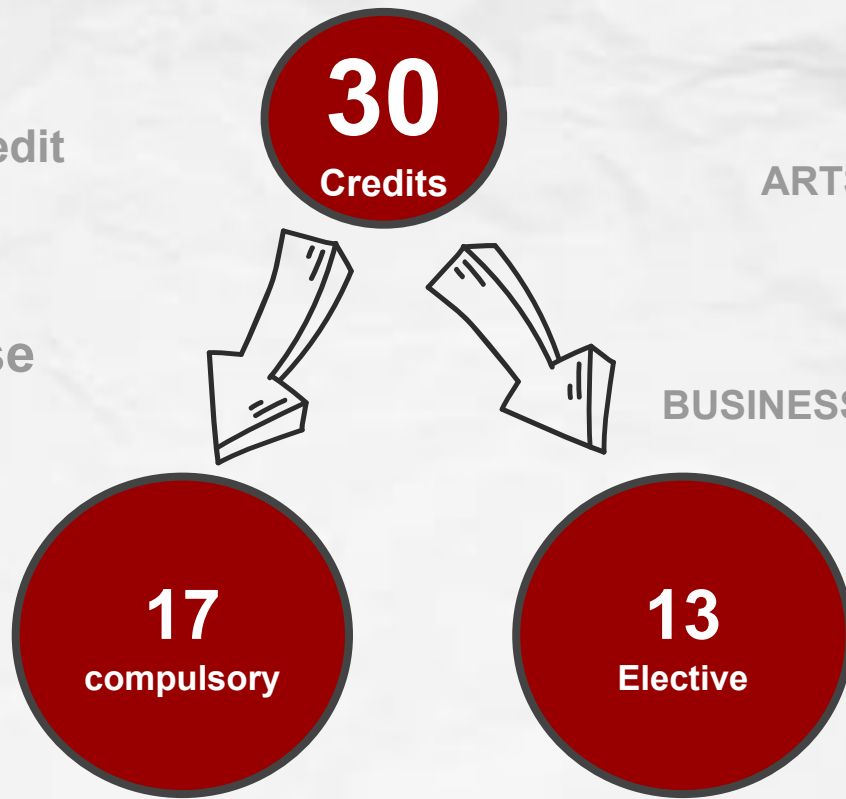

ARTS

Drama
Guitar
Instrumental Music
Vocal Music
Media Arts
Dance
Visual Arts

BUSINESS

Arts and Crafts
Launching and
Leading a Business

P.E.

Personal Fitness
PEAT
Healthy Active Living
Construction
Tech Design
Hospitality
Com. Technology
Green Industries
Transportation
Hairstyling

WHAT'S NEXT?

[Future Phoenix](#) [Parents](#) [Academics](#) [Student Services](#) [Student Life](#) [About](#)



Today ▶ Tuesday, January 31 ▼ Print

Tuesday, January 31
Period 3&4 Culminating
Wednesday, February 1
Period 5 Culminating
Thursday, February 2
Groundhog Day
Rescue/Recovery Day
12:30pm Staff Meeting
Friday, February 3
PA Day
Monday, February 6
First Day of Semester 2

[Google Calendar](#)



MyBlueprint



My Applications

MyBlueprint

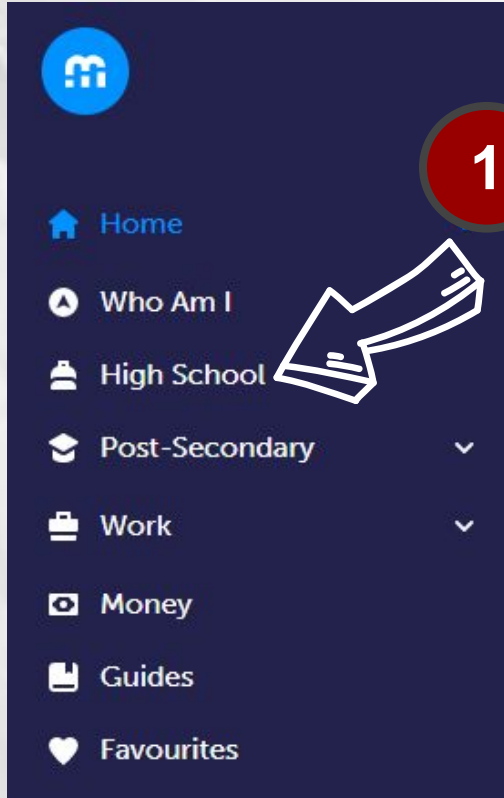

MyBlueprint

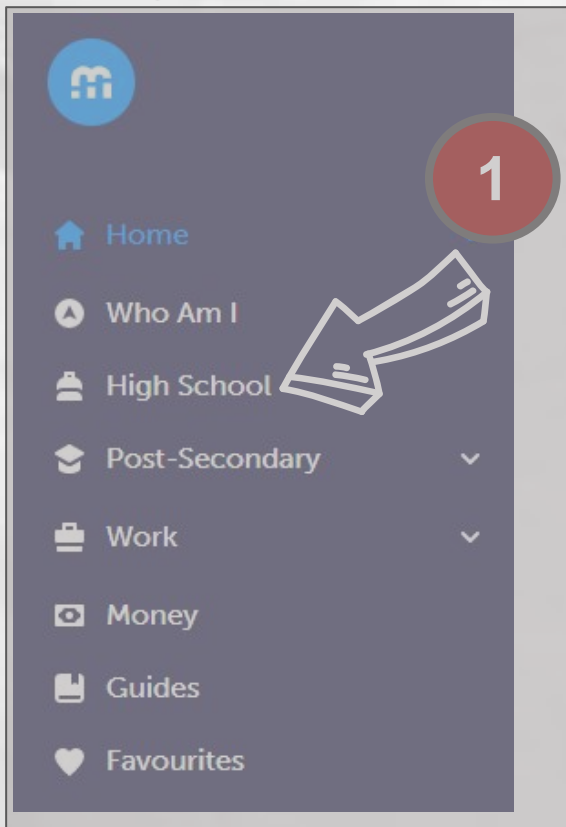

1

- Home
- Who Am I
- High School
- Post-Secondary
- Work
- Money
- Guides
- Favourites

Resurrection Catholic Secondary School



Grade 9 Plan Ahead	Grade 10 Plan Ahead	Grade 11 Plan Ahead	Grade 12 Plan Ahead	
De-streamed English ENL1WI • 1 Credit	+ English	+ English	+ English	
Academic Geography CGC1DI • 1 Credit	+ History	+ Mathematics	+ Religion	
Religious Studies HRE1OI • 1 Credit	+ Religion	+ Religion	+ Course	
Academic French FSF1DI • 1 Credit	+ Careers/Civics	+ Course	+ Course	
De-streamed Mathematics MTH1WI • 1 Credit	+ Mathematics	+ Course	+ Course	
De-Streamed -Science SNC1WI • 1 Credit	+ Science	+ Course	+ Course	
Drama ADA1OI • 1 Credit	+ Elective	+ Course	+ Course	
Healthy Active Living - Ma... PPL1OM • 1 Credit	+ Elective	+ Course	+ Course	

MyBlueprint

Resurrection Catholic Secondary School

3



✖ Your courses are **Not Submitted**

[Not returning next year?](#)

1 Step 1
Add Courses

2 Step 2
Review Courses

3 Step 3
Submit Courses

[Review Course Selections](#)

Grade 9 Current Year	Grade 10 Next Year	Grade 11 Plan Ahead	Grade 12 Plan Ahead	+
De-streamed English ENL1WI • 1 Credit	Applied English ENG2PI • 1 Credit	English	English	
Exploring Canadian Geogr... CGC1WI • 1 Credit	Applied History CHC2PI • 1 Credit	Mathematics	Religion	
Religious Studies HRE1OI • 1 Credit	Religious Education HRE2OI • 1 Credit	Religion	Course	
Academic French FSF1DI • 1 Credit	Civics/Careers Placeholder CIVCAR • 1 Credit	Course	Course	
De-streamed Mathematics MTH1WI • 1 Credit	Applied Mathematics MFM2PI • 1 Credit	Course	Course	
De-Streamed -Science SNC1WI • 1 Credit	Applied Science SNC2PI • 1 Credit	Course	Course	

MyBlueprint

Resurrection Catholic Secondary School

3 

✖ Your courses are **Not Submitted** Not returning next year?

1 Step 1 Add Courses **2** Step 2 Review Courses **3** Step 3 Submit Courses [Review Course Selections](#)

Grade 9 Current Year	Grade 10 Next Year	Grade 11 Plan Ahead	Grade 12 Plan Ahead
De-streamed English EH1L1W1 • 1 Credit	Applied English ENG2P1 • 1 Credit	English	English
Exploring Canadian Geogr... CGC1W1 • 1 Credit	Applied History CHC2P1 • 1 Credit	Mathematics	Religion
Religious Studies HRE1O1 • 1 Credit	Religious Education HRE2O1 • 1 Credit	Religion	Course
Academic French FSF1D1 • 1 Credit	Civics/Careers Placeholder CIVCAR • 1 Credit	Course	Course
De-streamed Mathematics MTH1W1 • 1 Credit	Applied Mathematics MFM2P1 • 1 Credit	Course	Course
De-Streamed -Science SNC1W1 • 1 Credit	Applied Science SNC2P1 • 1 Credit	Course	Course

4 

Review Courses

1 Review your course selections before submitting. Once submitted, you can no longer make changes in myBlueprint.

1 Step 1 Add Courses **2** Step 2 Review Courses **3** Step 3 Submit Courses [Submit Course Selections](#)

1 Review Course Selections

- ✓ ENG2P1 Applied English
- ✓ CHC2P1 Applied History
- ✓ HRE2O1 Religious Education
- ✓ CIVCAR Civics/Careers Placeholder
- ✓ MFM2P1 Applied Mathematics
- ✓ SNC2P1 Applied Science

2 Add Comments

Add comments you would like to include

MyBlueprint

Resurrection Catholic Secondary School



Review Courses



✖ Your courses are **Not Submitted**

- 1 Step 1 Add Courses
- 2 Step 2 Review Courses
- 3 Step 3 Submit Course Selections

submitted, you can no longer make changes in myBlueprint.

Submit Course Selections

Step 3
Submit Courses

2 Add Comments

Add comments you would like to include

✖

Parent/Guardian Approval

Please add a parent or guardian email below for us to share your course selection.
Your parent/guardian will be asked to approve your course selections.

Parent/Guardian Email

Send Approval Email



Grade 9 Current Year	Grade 10 Next Year
De-streamed English EH1L1W1 • 1 Credit	Applied English ENG2PI • 1 Credit
Exploring Canadian Geogr... CGC1W1 • 1 Credit	Applied History CHC2PI • 1 Credit
Religious Studies HRE1O1 • 1 Credit	Religious Education HRE2O1 • 1 Credit
Academic French FSF1D1 • 1 Credit	Civics/Careers Placeholder CIVCAR • 1 Credit
De-streamed Mathematics MTH1W1 • 1 Credit	Applied Mathematics MFM2PI • 1 Credit
De-Streamed -Science SNC1W1 • 1 Credit	Applied Science SNC2PI • 1 Credit

DEADLINE



Feb. 28

Tech courses are first
come first served
based on limited
facilities

SUPPORTS

Parents

Teachers

Guidance



LAST NAME	GUIDANCE	EMAIL
A - CH	Mr. Kritz	sean.kritz@wcdsb.ca
Ci- Gi Intern'l	Ms. Iley	nadine.iley@wcdsb.ca
Gl - Ma	Ms. McQuinn	cathy.mcquinn@wcdsb.ca
Mc - R ELD	Mr Meyer	nathan.meyer@wcdsb.ca
S - Z	Ms. Jayasundera	kishanie.jayasundera@wcdsb.ca

